

MODEL KPT-3868 3/8" Drill

Chuck Size	10 mm
Spindle Thread	3/8"-24
Free Speed	1800 rpm
Net Weight	0.9 kg
Overall Length	195 mm
Air Consumption	747 L/min
Air Inlet	1/4"

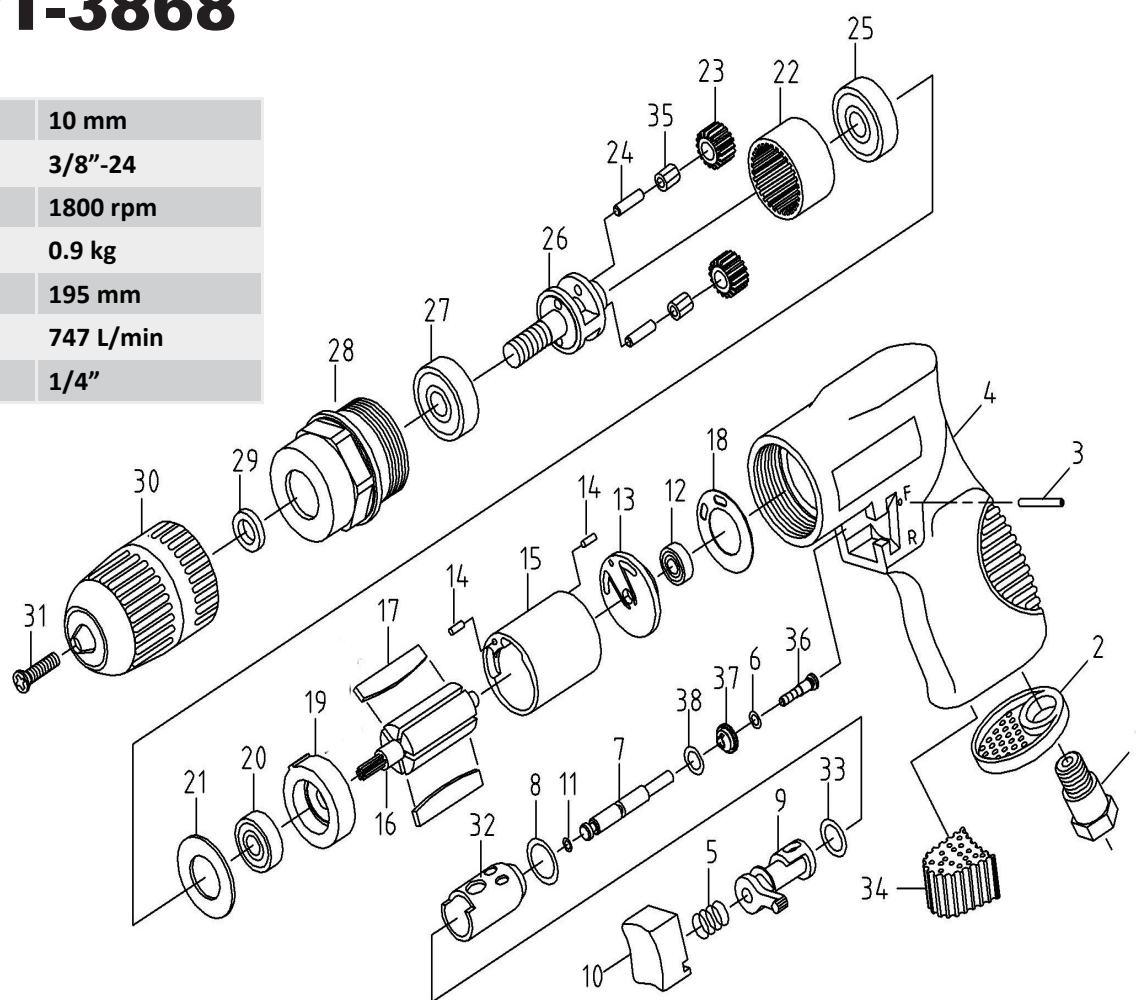

Parts List

NO.	Parts Name	Q'ty	NO.	Parts Name	Q'ty
1	AIR INLET	1	20	BEARING (608ZZ)	1
2	EXHAUST SLEEVE	1	21	WASHER	1
3	PIN(2.5*24)	1	22	GEAR LINK	1
4	HOUSING	1	23	GEAR	2
5	SPRING	1	24	PIN	2
6	O-RING (2*1 NBR70)	1	25	BEARING (6001Z)	1
7	VALVE STEM	1	26	GEAR PLATE	1
8	O-RING (P12.5)	1	27	BEARING (6200ZZ)	1
9	REVERSE LEVER	1	28	CLAMP NUT	1
10	TRIGGER	1	29	WASHER	1
11	O-RING (3.5*1.4)	1	30	3/8" JACOB KEYLESS	1
12	BEARING (696ZZ)	1	31	CHUCK SCREW	1
13	REAR PLATE	1	32	BUSHING	1
14	PIN(2.5*6)	2	33	O-RING (P11)	1
15	CYLINDER	1	34	MUFFLER	1
16	ROTOR	1	35	NEEDLE BEARING	2
17	ROTOR BLADE	5	36	VALVE STEM	1
18	PACKING	1	37	VALVE STEM BUSHING	1
19	FRONT PLATE	1	38	O-RING(AS010)	1